

TANGO 31 (TA-31883)



Product description

Ø186 - 288 mm - Down (Optic)
& Up (Optic 2nd) - Round



Luminaire structure

- Die-cast aluminium housing and frame
- Pre-treated before powder coating ensuring high corrosion resistance
- Single cable entry
- Stainless steel fasteners in grade 304 with zinc flake coating (ZFC)
- Durable silicone rubber gasket
- Clear toughened glass
- High-efficiency optical reflector
- Integral control gear
- Optional surface mounting box for easy wiring or conduit connection when wiring from behind is not possible

Light symbol

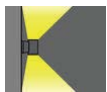

AS / AS

Product colour



01- Black (RAL 9011) 02- Dark Grey (RAL 7043) 03- White (RAL 9003) 05- Matt Silver (RAL 9006)



06- Bronze (RAL 6014)

Special finishes upon request



SU01- Concrete Urban SU02- Softscape Urban SU03- Stone Urban SU04- Corten Urban



SW01- OAK Woodland SW02- Walnut Woodland SW03- PINE Woodland

Technical information

Light source	1 & 1 COB
Light source type	COB
Dimming type	DALI, On/Off
Material	Aluminium
Weight	6.4 kg
Operating temperature	-20°C to 40°C

Luminaire	
Power	58 W
Lumen	5070 - 5132 lm
Efficacy	87 - 88 lm/W
CCT / CRI	3000K CRI80, 4000K CRI80
Drive current	700 mA
Driver option	Integral control gear
Driver	Constant current (CC)
Input voltage	220-240 V 50/60 Hz

Optic	AS [46°x56°]
Optic (Up)	AS [46°x56°]
MacAdam Ellipse	3 SDCM
Lifetime L90B10 (hrs)	55,000

TANGO 31 (TA-31883)

Product variants

HOW TO SPECIFY

LIGA	- TA-31883	- 700	- AS	- AS	- 8030	- ND	- 01
MODEL	OUTPUT	DISTRIBUTION		CRI/CCT	DIMMING	COLOUR FINISH	
DOWN-UP							
TA-31883	700 58W	AS	AS	8030	ND	01 BLACK	
				8040	DALI	02 DARK GREY	
						03 WHITE	
						05 MATT SILVER	
						06 BRONZE	
						S- SPECIAL FINISH	

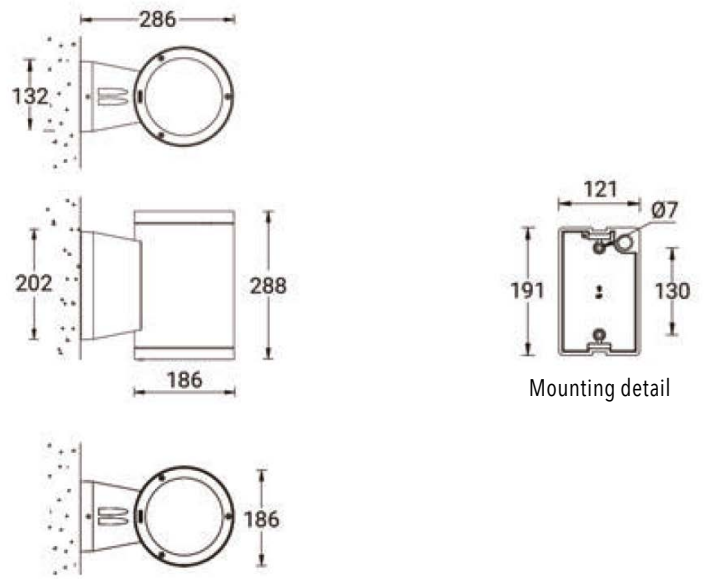

Accessories



Surface mounting box for easy cabling (TANGO 31)
LIGA-SCE-TANGO-31